

CX-91S TDS Series Magnetic Locks

INSTALLATION INSTRUCTIONS



SECURITY
UL LISTED
 UL 1034 / UL 294
 Standard for
 Burglary-Resistant
 Electric Locking
 Mechanisms

CA
CA
 ULCS 533-15
 Standard for
 Access and Egress

1. SPECIFICATIONS

	CX-91S-06-TDS	CX-91S-12-TDS
Static Strength	600 lbs. (Factory Tested) ** 500 lbs. (UL Verified)	1200 lbs. (Factory Tested) ** 1000 lbs. (UL Verified)
Dynamic Strength	50 ft-lb	70 ft-lb
Voltage Input	12/24V DC	12/24V DC
Current Draw	510mA/285mA	500mA/265mA
Dimensions (Body)	9-7/8"W x 2"H x 1"D (250mm x 50mm x 25mm)	10-1/2"W x 2-5/8"H x 1-1/2"D (266mm x 67mm x 39mm)
Dimensions (Armature Plate)	7-5/32"W x 1-3/4"H x 15/32"D (182mm x 44mm x 12mm)	7-9/32"W x 2-13/32"H x 5/8"D (185mm x 61mm x 16.5mm)
Endurance	250 000	250 000

Performance Levels

- Destructive Attack = Level I
 - Line Security = Level I
 - Standby Power = Level I
 - Endurance = Level IV
- (Relay Source #2 and #3)

2. BASIC INSTALLATION CONCEPT & ACCESSORIES (FIGURE 1)

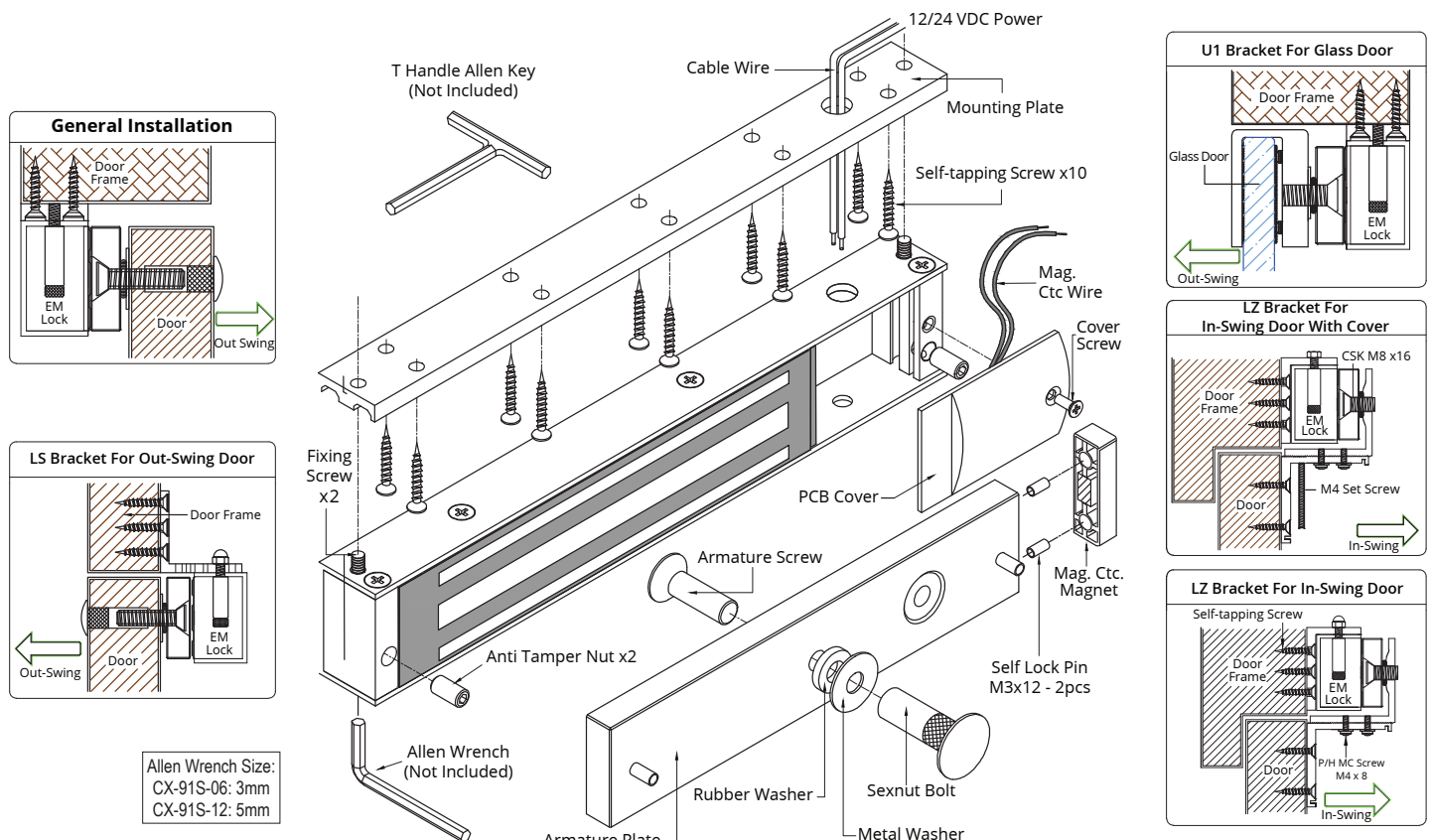

CX-91S TDS Series Magnetic Locks

INSTALLATION INSTRUCTIONS

3. INSTALLATION

1. Drill the armature plate holes in the door using the sticker template provided.
2. Attach the armature plate to the door with the hardware provided as per Figure 2.3.
3. With the door closed, mark the door frame at the edge of the armature in order to properly align the electromagnet to the armature.
4. Attach the mounting plate to the door frame using the self-tapping screws provided.
Align the mounting plate with the mark from Step 3.
5. Insert the wires through the hole in the mounting plate and into the electromagnet unit. Attach the electromagnet unit to the mounting plate with the Allen head fixing screw.
6. Screw in the anti-tamper nuts to prevent unauthorized access and make sure to fully tighten the fixing screw with proper tool. A "T" Handle Allen Key (Allen Wrench 3mm for CX-91S-06 and 5mm for CX-91S-12).
7. The electromagnetic lock must be installed in accordance with the following :
 - Life Safety Code ANSI / NFPA 101.
 - Local Authority having Jurisdiction.
 - Manufacturer's installation instructions provided with each unit.
 - The power supply units must be mounted inside the secured or protected area.
8. Connect the magnetic contact wire to the door monitoring system; according to the system guide. Door status switch is mounted on the back of the PCB cover plate.
9. Typical wiring method shall be in accordance with CSA C22.1, Canadian Electrical Code, Part I, Safety Standard for Electrical Installations, Section 32.

Note:

- Install in indoor dry location.
- Use caution when changing factory default setting.
- It is recommended to apply a light coat of silicon lubricant to the mating surface on a monthly basis to prevent rust.
- Manufacturer's Instructions provided in each unit.

NOTICE:

All models are recognized to:
UL 294 and ULC S533-15 : Standard for Access & Egress.

Models CX-91S-06 & CX-91S-12 are listed to:
UL 1034, Standard for Burglary-Resistant Electric Locking Mechanism.
UL 294, Access Control System Units

** Value not verified by UL.

Remark:

All drawings shown are for illustration purpose only.
Actual product may vary due to product enhancement.

4. TROUBLESHOOTING

1. Sensor not functioning:
 - Improper attachment of electromagnet and armature plate.
 - Modification of the PCB
2. Door not locked:
 - Incorrect wiring or no power from power supply
3. Reduced holding force:
 - Poor contact of electromagnet and armature
 - Be sure armature is loose enough that it can fully contact electromagnet along the entire length
 - Mating surface is dusty or damaged
 - Improper input voltage or wire size.

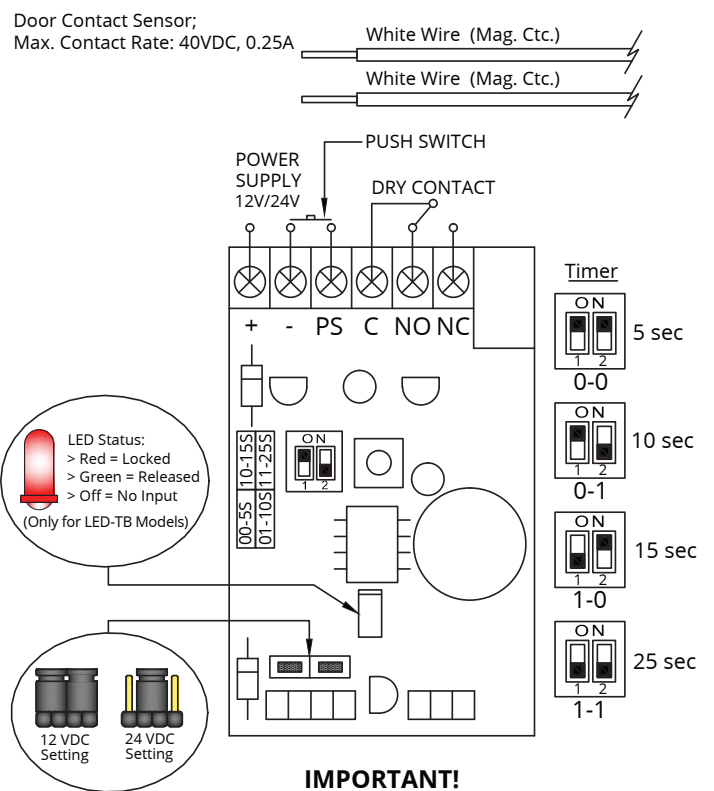

5. REGULAR INSTALLATION GUIDE (FIGURE 2)

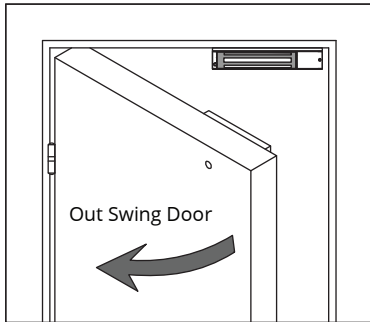

1 Installation Template

Fold the CX-91S Template along the dotted line upto 90°.

Note: Installation Template Only for In-door E.M. Lock Model 300, 600, 1200

2 Door Frame
Door Template

Close the door, position the EM lock mounting location as close to the door upper corner with gap 10mm.

3 Door Frame
Door

Place the template against the door & frame and drill holes according to template indications.

4 Door Frame
Door

Drill 2 holes on Frame and 3 holes on door as indicated on the template.

5 Armature Screw
Armature Plate
Sexnut Bolt
Metal Washer
Rubber Washer

Wooden Door

Install the Armature Plate to the door.

Note: Actual installation may varies according to door figures.

6 Door
Rubber Washer

This allow the armature plate to pivot around the armature screw to compensate for door misalignment.

7 Door Frame

Mount the FB600 on the door frame by screw in the self tapping screw on the holes as indicated on template.

8 Door Frame
Door

Once position is correct, screw in others screws to permanently mount the plate; and drill the wire cable access hole.

9 Cable Wire
Cover Screw
Fixing Screw x2
PCB Cover
Anti Tamper Nut x2
Allen Wrench

** T Handle Allen Key 3mm
Not Included

Use an Allen key wrench to unscrew the anti tamper nut and tighten the fixing screws on the mounting plate.

10 Door Frame
Door
EM Lock

Connect to power supply and test unit.

CX-91S TDS Series Magnetic Locks

INSTALLATION INSTRUCTIONS

6. LZ BRACKET FOR IN-SWING DOOR INSTALLATION GUIDE (FIGURE 3)

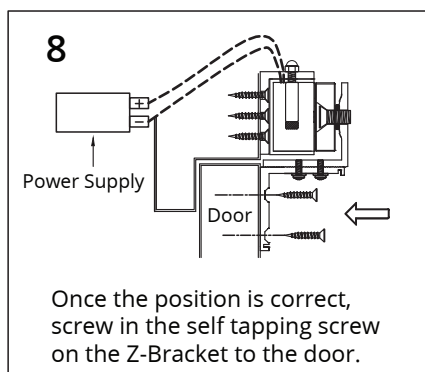
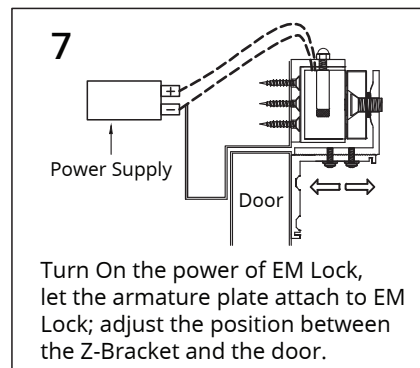
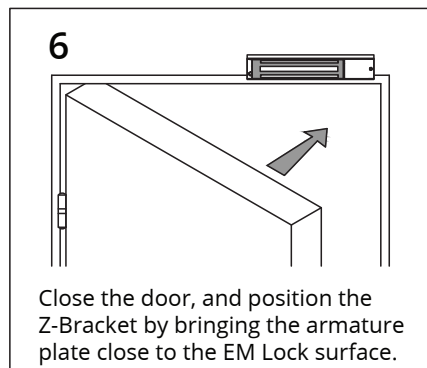
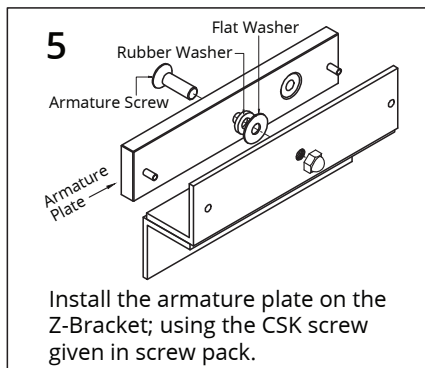
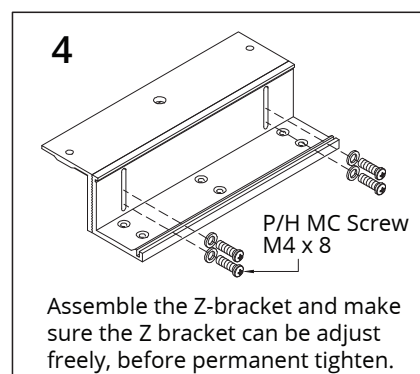
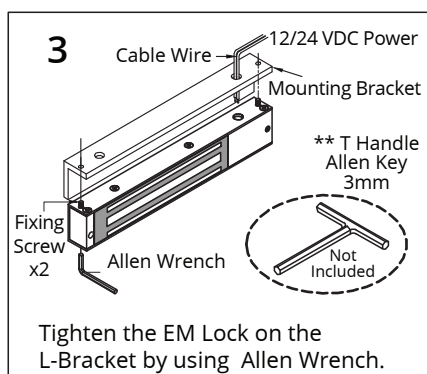
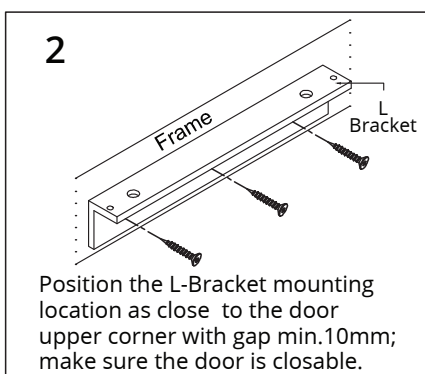
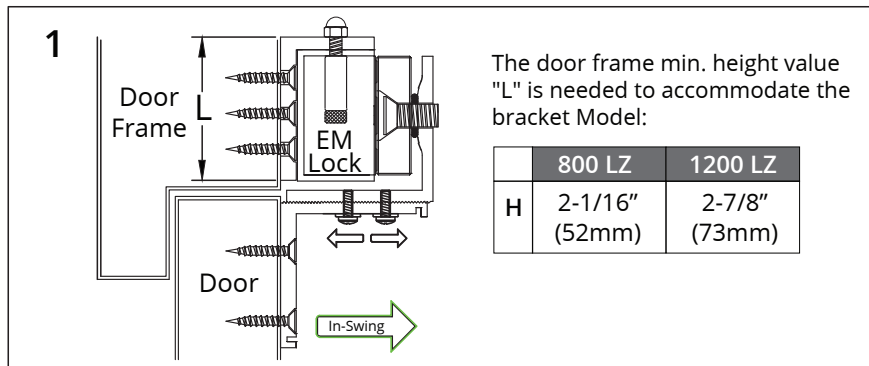
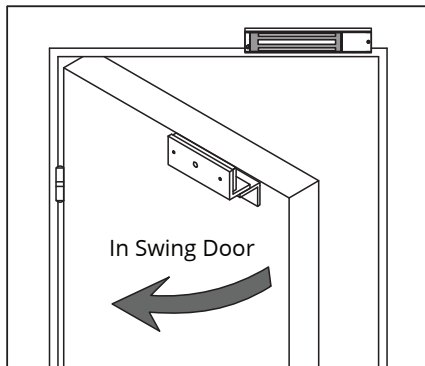

Distance in feet from power supply to the furthest lock unit

Amps	25f	50f	75f	100f	150f	200f	250f	300f	400f	500f	1000f
0.25	18	18	18	18	18	16	16	14	14	12	
0.50	18	18	18	16	16	14	12				
0.75	18	18	16	14	12	12					
1.00	18	16	14	14	12						
1.50	18	14	12	12							
2.00	16	14	12								

Amps	25f	50f	75f	100f	150f	200f	250f	300f	400f	500f	1000f
0.25	18	18	18	18	18	18	18	18	16	16	16
0.50	18	18	18	18	18	16	16	14	14	12	
0.75	18	18	18	18	16	14	14	12	12		
1.00	18	18	16	16	14	14	12	12			
1.50	18	18	16	14	14	12					
2.00	16	16	14	14	12						